

Size Range 120 x 120 x 38 mm 4,72 x 4,72 x 1,5 " EC AXIAL FAN

### TECHNICAL DATA

#### Characteristics

- Weight: 0,33 Kg / 0,73 Lb
- Housing in plastic UL 94 V-0
- Turbine in plastic UL 94 V-0
- L-10 life expectancy at 40°C: 80.000 hours
- Operating temperature range: -20 / +70 °C
- Storage temperature: -40 / +70°C
- Connection: Leads
- Integrated circuit
- IP20
- PWM

#### Options

- Speed sensor
- Alarm
- Other IP levels
- Salt spray protection
- Shocks and vibrations protection

### ELECTRICAL AND AERAILIC DATA

Part Number	Voltage range	Frequency	Airflow		Pressure		Nominal speed	Noise level LP	Nominal current	power
	V	Hz	l/s	CFM	mm H <sub>2</sub> o	inch H <sub>2</sub> o	RPM	dBA	A	W
125ESZLP11600	85-265	50/60	54,70	115,96	11,22	0,44	3480	53	0,08/0,15	8,00

### DRAWING AND AIRFLOW CURVE

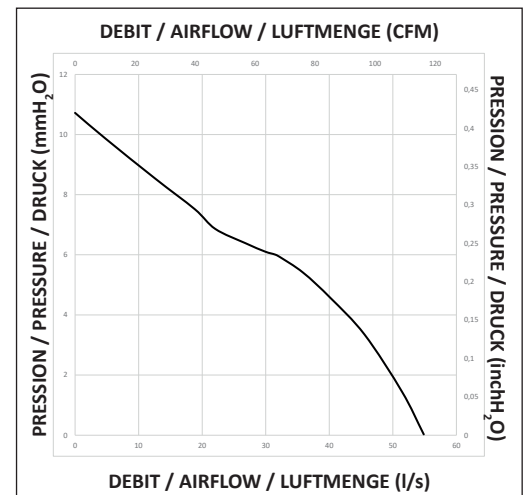
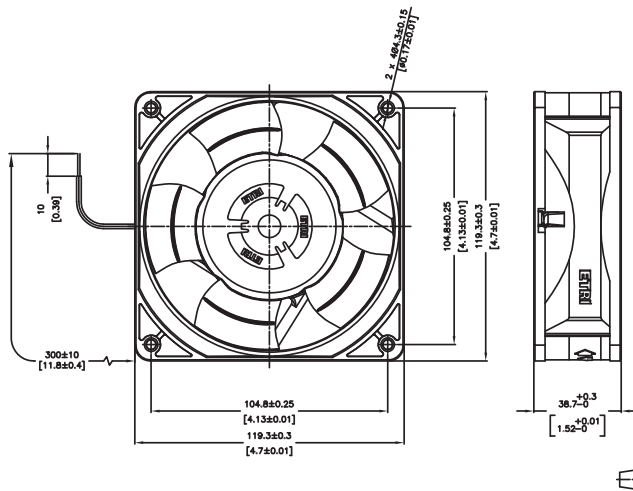

Non contractual document. All specifications are subject to change without prior notice. For professional use only. Please refer to the conditions of use of our catalogue.